

Fenix

by Enervent

Fenix is a ventilation unit with cross-flow heat exchanger designed for buildings with no attic space (for example high-rise buildings, apartments and terraced houses).

The unit should be placed in a warm (over +5°C) space.

Fenix by Enervent

Ventilation unit with heat recovery

General

The Enervent company, known for its ventilation units with rotating heat exchangers, introduce our new ventilation unit with cross-flow (or "plate") heat exchanger to the market.

To address demands for a high-quality, value for money ventilation unit suitable for high-rise buildings, apartments and terraced houses, we created Fenix. The origins of the Fenix can be found in the Enervent Pro-series, where ventilation heat recovery units with plate heat exchangers have been manufactured for years. This gained experience is now applied to the Enervent Family range of home ventilation units. The elegant looks and high quality distinguish the Fenix unit as made by Enervent.

Three sizes

The Fenix unit is manufactured in three sizes: Fenix 60 with 105 W fans, Fenix 85 with 130 W fans and Fenix 120 with 185 W fans.

Installation

The unit is installed in a warm (over +5°C) space on the wall or in the ceiling. A mounting plate for ceiling installation is also available. The unit is equipped with a cross-flow plate heat exchanger, summer/winter (or "bypass") damper, 1000 W electrical boost heater and EU5 bag filters.



Fenix 120 measurements

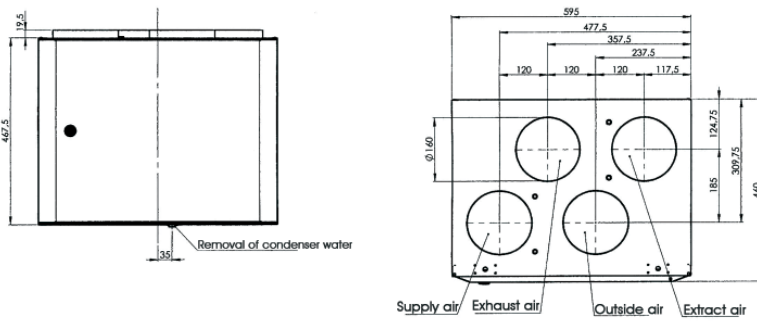

Fenix 120 specific curves

FENIX (185W) SUPPLY AIR EU4/5 plain filter
Specific curve with different transformer outputs
1,2,3 and 4 factory settings

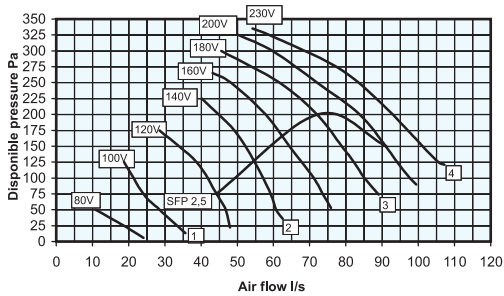

FENIX (185W) EXHAUST AIR EU4/5 plain filter
Specific curve with different transformer outputs
1,2,3 and 4 factory settings

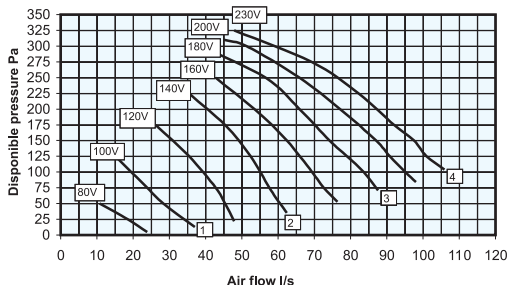

All rights reserved.

Fenix technical data

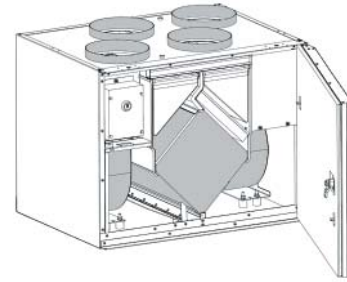

Duct size	Ø 160 mm
Depth	460 mm
Width	595 mm
Height	467,5 mm
Weight	45 kg
Heat exchanger	Cross-flow heat exchanger
Heat recovery by-pass	Summer/winter damper
Booster heater	1 000 W electrical heater
Filters	EU5 bag filters
Fans	105 W / 130 W / 185 W
Current	230 V / 50 HZ 1~
Fuse	10 A quick

All rights reserved.

Enervent family ventilation units



LTR-3
+110, -110 l/s

LTR-6
+230, -230 l/s

LTR-7
+390, -390 l/s

Cut your energy costs!
Choose an energy efficient Enervent Family ventilation unit with rotating heat exchanger.



Pingvin
+ 87, -95 l/s

Pandion
+ 140, -140 l/s

Pelican
+190, -205 l/s

Pegasos
+ 370, -370 l/s



Enervent
Unit 3F, Maynooth Business Campus, Maynooth,
Co. Kildare, Ireland
Ph: +353 (0)1 6290621 Fax: +353 (0)1 6290623
www.enervent.ie sales@enervent.ie

Dealer: